

OPERATING INSTRUCTIONS

VARIMANT-1 VARIMANT-2

VARIMANT-4 Plus



ULV- Applicator for weed control
in areas of specialised cultivation such as nurseries, orchards and
vineyards, ornamental plant and vegetable gardens, as well as
agricultural, forestry, communal and non-cultivated lands.

The unit has been developed for the *undiluted*
application of ROUNDUP® products (Glyphosate).

Important:

Before application, carefully read the usage instructions for the unit and the plant protective agent!
Observe safety instructions!

For questions regarding plant protective agents, consult the manufacturer!

Observe the requirements and regional regulations for the use of herbicides and, if necessary,
obtain approval from the responsible authorities (e.g. environmental conservation agency)!

Application is to be performed only by a competent user.

Remarks about usage of the unit:

Settings: This system is not suitable for the application of water.
Use herbicides for testing the spray action and calibration of the
flow rate.



Keep the applicator and pesticides out of the reach of children.

Noise emission from the unit equates to less than 70 dB(A).

Manufacturer:

Mantis ULV-Sprühgeräte GmbH
D-21502 Geesthacht,
Telephone + 49 (0)4152 / 8459-0,
Internet: www.mantis-ulv.eu

Vierlander Str. 11 a
FAX + 49 (0)4152 / 8459-11
E-Mail: mantis@mantis-ulv.eu

VARIMANT

For the undiluted application of Roundup® products (Glyphosate)

The instructions on this page are valid for all VARIMANT applicator units. Details regarding assembly, use and replacement parts are provided on the following pages:

VARIMANT-1, VARIMANT-4 Plus:	VARIMANT-2:	Pages 4-5 Pages 6-7
---------------------------------	-------------	------------------------

Intended usage:

Weed control in areas of specialised cultivation such as nurseries, orchards and vineyards, ornamental plant and vegetable gardens, as well as agricultural, forestry, communal and non-cultivated lands.

Before application, carefully read the usage instructions for the applicator unit and pesticides.

Observe safety instructions.

For questions regarding pesticides, consult the manufacturer!

Observe the requirements and regional regulations for the use of herbicides. Permission is required from the responsible authorities (e.g. environmental conservation agency) for the application of herbicides on surfaces used for non-agricultural, forestry or gardening purposes ("non-cultivated lands"). Application is not permitted on sealed surfaces (e.g. pavement surfaces) with connection to sewage water systems from which the danger of run-off exists! Application is to be carried out only by a competent user.

Noise emission from the unit equates to less than 70 dB (A).

Protective measures

Observe the remarks in the pesticide usage instructions regarding user safety and wear recommended body protection. Wear protective gloves when filling the chemical substance.

Do not eat, smoke or drink while working with pesticides. Avoid chemical spillage without fail. Thoroughly clean hands and face after completion of work.

Thoroughly clean and dry the unit immediately following its usage. Never use the mouth to blow out nozzles or other small parts!



Keep pesticide applicators and chemical substances away from children.

Assembly and preparation for initial application

Unit assembly is described for the individual models. Assembly of the spray hoods according to the draft on page 5. and connect all plugs. Please connect the hoses not until the output volume is checked. To check the spray width place underlay (cardboard or paper) on the ground and select a output quantity.

General remarks regarding applicator unit function and deployment

Pesticides: This applicator unit was originally designed for the undiluted application of Roundup products (Glyphosate). Practical experience has shown, however, that other herbicides can also be deployed in conjunction with this technology. Considering the many products on the market with their differing formulations, it is not possible to provide a complete list with application rate recommendations. Specifications for adjusting the unit listed on following pages relate to the usage of Roundup UltraMax (Glyphosate 450 gr/ltr). In general, all products with a comparable viscosity are suitable. If it is intended to use a product other than Roundup UltraMax, its application should be first tested over a small area on a trial basis. Usage instructions for the chosen herbicide should be observed in every case, along with local requirements.

Applicator unit function: Rotating atomisers are driven by means of a rechargeable battery. Metering on all the units mentioned is path-dependent and takes place by means of a wheel driven pump. Droplets are formed by the centrifugal force of the rotating atomiser. The droplets are discharged downwards by the rotating atomiser through a continuously variable, adjustable segment. Residual chemical in the tank not intended for application is approx. 50 ml. This residual fluid can be refilled back into the original herbicide container.

Checking applicator unit function: Chemical solutions may flow quicker or slower due to temperature fluctuations, for which reason the flow rates in the Metering table should be checked and corrected as necessary. This system is not suitable for the application of water. Please use herbicides at all times for testing the spray process and calibrating the flow rate. Check the rotating atomiser on a daily basis for cleanliness and free turning motion. Check the output volume from time to time throughout the season.

Deployment of the applicator unit: Adjust the height of the spray hood in such a manner that it is as close to the ground as possible - if it is set too high, the risk of spray driftage exists. During operation, chemical fluid will collect in the rotating atomiser reservoir and will continue to drip for approx. 30 seconds after the shut-off valve has been closed if the unit is tilted. In order to avoid damage to cultivated plants due to dripping, we recommend closing the shut-off valve at the end of a row, for example, then folding the spray hood upwards and waiting approx. 30 seconds until the reservoir has emptied.

Spray width

- Place an underlay (cardboard or paper) on the ground and prop up the unit on stands.
- Actuate the switch button on the powerpack while simultaneously turning the wheel and appraising the spray width obtained, initially at one location. The spray width must be set in such a manner that the droplets are discharged over the entire width of the spray hood. The optimal spray width under standard operating conditions is set by the manufacturer.
- Compensate for deviations is possible by loosening screw (F) and sliding the width adjustment on the atomiser (see drawing).
- Further details regarding operating width adjustment can be found on the respective pages for the individual applicator units.

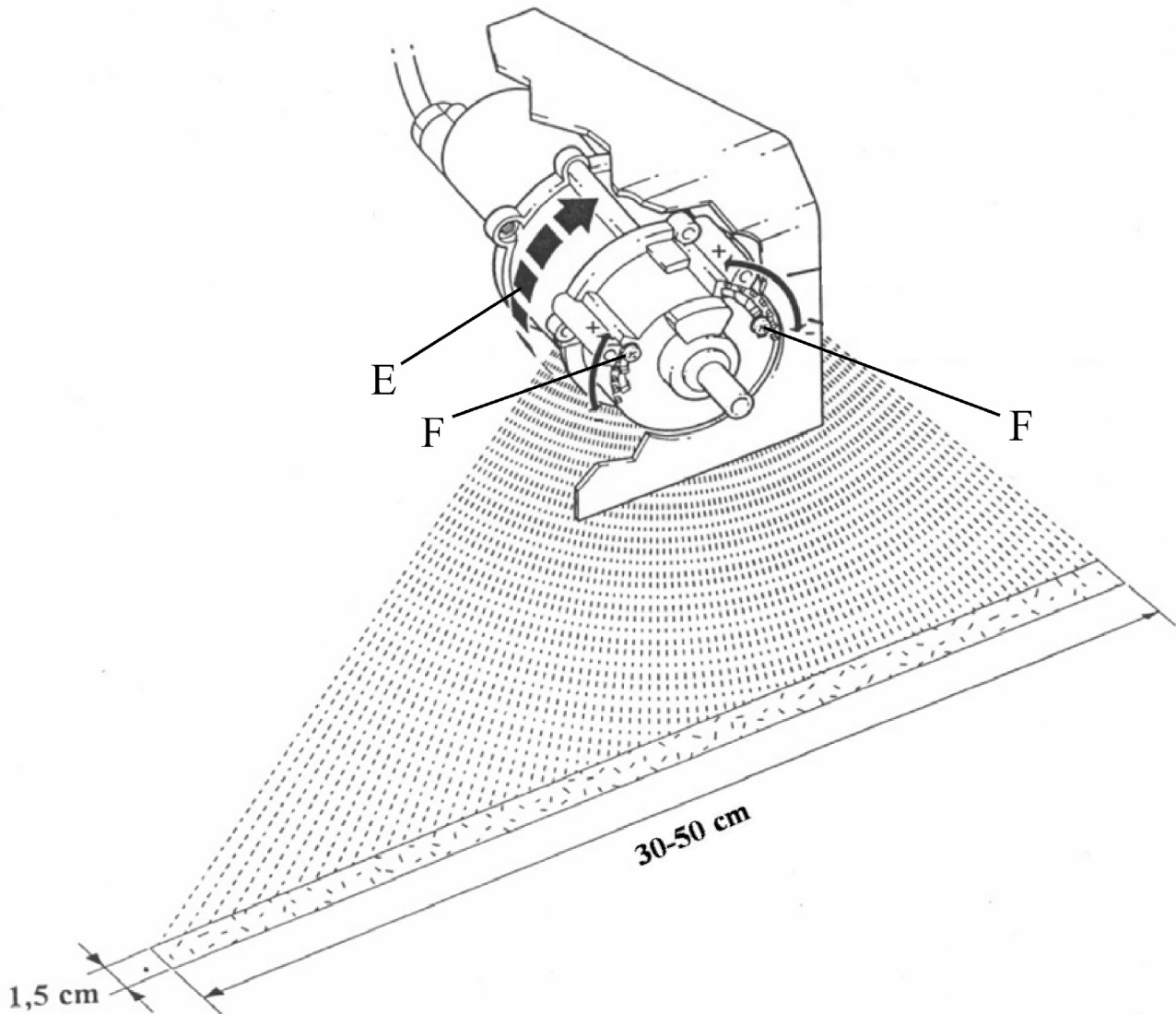

Cleaning

Do not clean the applicator unit with a high-pressure sprayer or with an intense water jet spray.

Cleaning during the season: During short work breaks (a few hours), herbicide can remain in the system as long as the shut-off valve remains closed. After work completion: before cleaning, refill the chemical solution into its original container. Open the shut-off and set the metering pump to maximum. Fill the chemical tank halfway with water, then, with the unit positioned, turn the wheel smoothly 50 x and allow the fluid to drain into a collector tank or, operating the unit for approx. 100 m, apply the cleaning fluid to the already treated surface. Remove any remaining water from the tank and turn the wheel 50 x once again until the system is completely empty.



Cleaning at the end of the season: Rinse the unit with warm water as described above. Additionally: Unscrew filter and clean screen as necessary. The spray hood and the atomiser housing can be cleaned with a moist cloth. Remove the atomiser disc in order to avoid damage. With heavy contamination, the atomiser housing should be unscrewed to remove contaminants and plant parts. Connect the unit to the charging device (see below).

VARIMANT-1 and VARIMANT-2

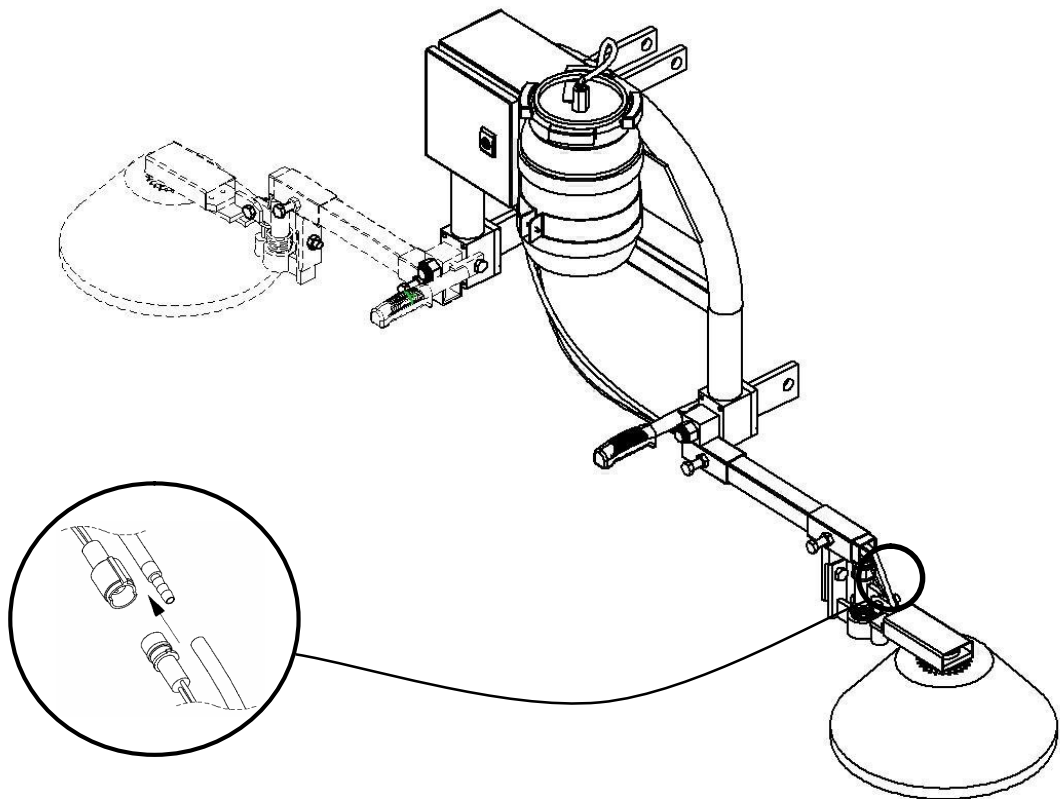

Assembly

1. Mount the spraying system on the vehicle.
2. Connect electrical plug 12 V-with the socket of the vehicle. Please check the vehicle polarity. If the plug is removed , blue lead is (+), brown lead (-).
3. Set ground clearance of the spray hood.
4. Connect control box with pump unit .
5. Check spray width of the atomiser. (see drawing page 3)
6. After checking the output volume (workflow on the right) connect all hoses.

Metering table

Roundup UltraMax application rate at 20°C

Dosing pump Mafex -3 Piston for VARIMANT-1

km/h	m/min.	l/ha	nominal value ml/min.	pump calibration
4	67	1	3,4	B
		1,5	5	C
		2	6,8	E
6	100	2	5	C
		3	7,5	F
		4	10	I
8	134	2	6,8	E
		3	10	I
		4	13,4	L

Checking the output volume

1. Place an underlay (e.g. cardboard or paper) on the ground and prop up the unit on stands.
2. Fill the chemical tank with herbicide –undiluted.
3. Open the pump box and set the chemical solution volume according to the output table.
4. Volume calibration: Collect the chemical solution in a metric measuring cup for one minute. If the desired volume is not reached, set a larger or a smaller volume with pump metering adjustment knob.
5. Perform volume calibration again.
6. Reconnect the hose
7. The unit is now ready for deployment

Dosing pump Mankar -3 Piston for VARIMANT-2

km/h	m/min.	l/ha	nominal value ml/min.	pump calibration
4	67	1	3,4	A
		1,5	5	C
		2	6,8	D
6	100	1	5	C
		1,5	7,5	E
		2	10	H
10	166	1	8,25	G
		1,5		
		2		

VARIMANT-1 and VARIMANT-2

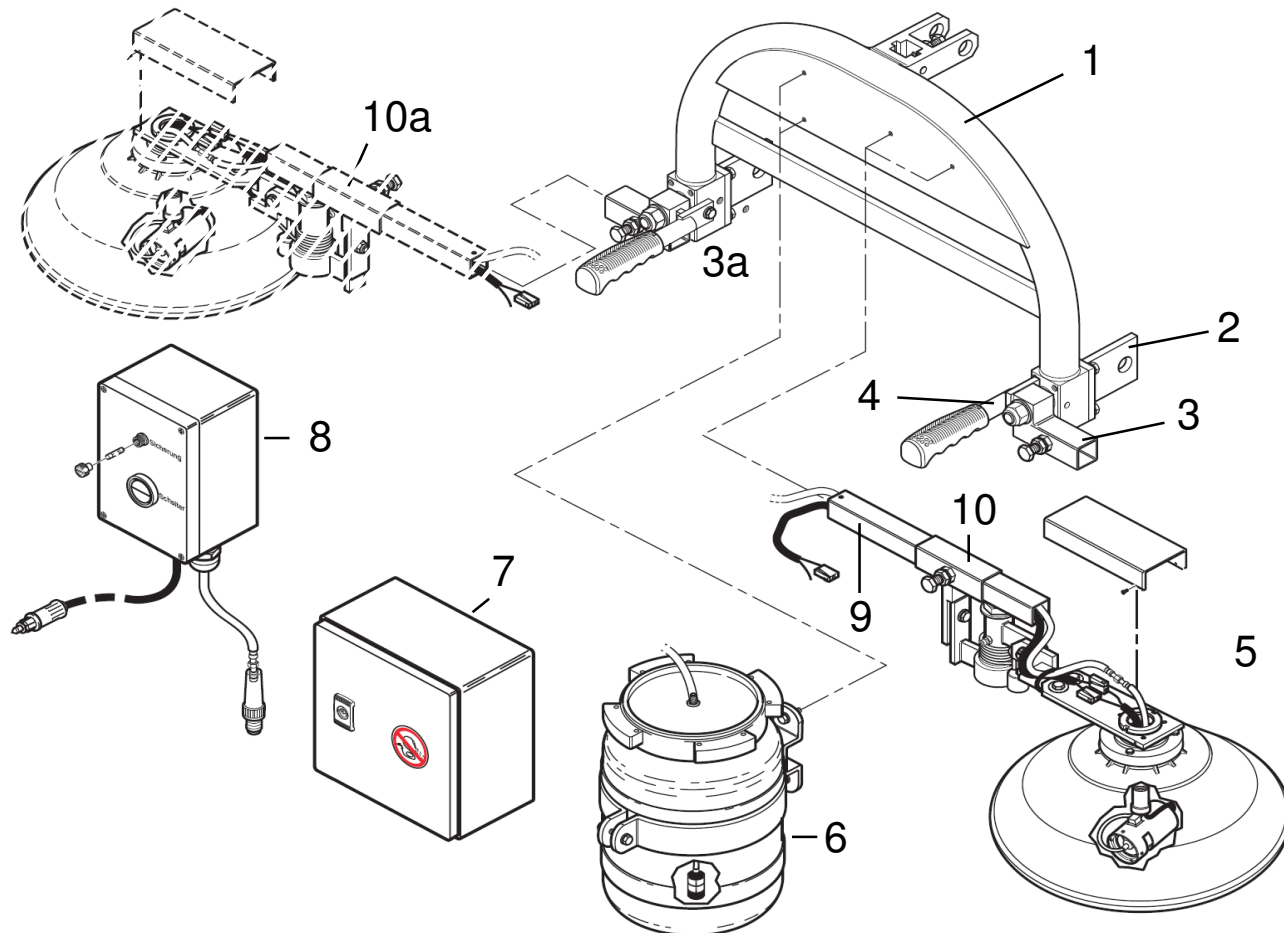

Item Part No. Description

1	101797	3-point hitch for VARIMANT/FLEXOMANT
2	101541	Lower link for 3-point hitch VARIMANT/FLEXOMANT
3	100676	Swivel VARIMANT, left side
3a	101550	Swivel VARIMANT, right side
4	100677	Adjustment with handhold
5	101265	Spray hood arm (K) 36 cm Version: plastics with atomizer
6	100589	Tank subassembly, consisting of: Tank 6L, tank holder, lid and filter for VARIMANT
7	100515	VARIMANT -1, Pump unit MAFEX-3 DC/DC Capacity 2 - 20 ml/min
7	100582	VARIMANT -2, Pump unit MANKAR-3 DC/DC, Capacity 2 x 5 - 12 ml/min
8	102224	Control box with 1 switch, without converter for VARIMANT
9	100671	Extension arm VARIMANT
10	101789	Width adjustment, left side
10a	101790	Width adjustment, right side

VARIMANT-4 Plus

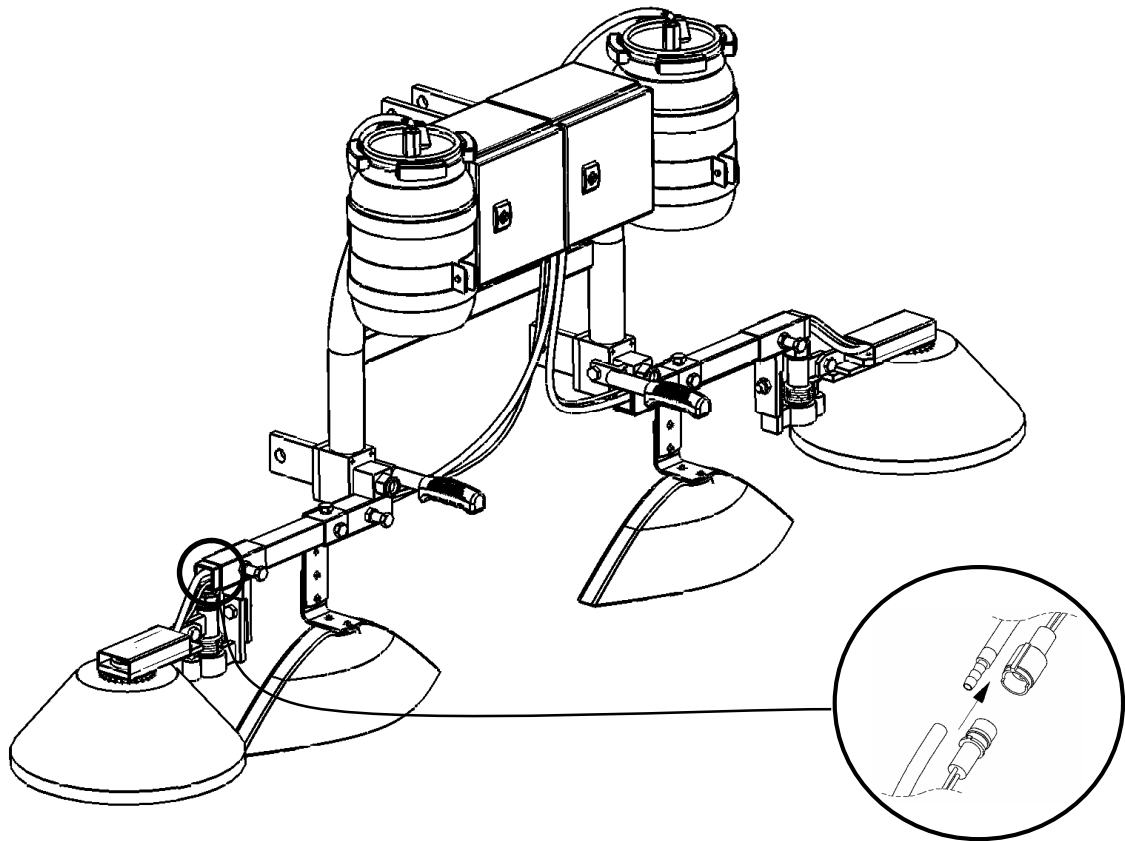

Assembly

1. Mount the spraying system on the vehicle.
2. Connect electrical plug 12 V-with the socket of the vehicle. Please check the vehicle polarity. If the plug is removed , blue lead is (+), brown lead (-).
3. Set ground clearance of the spray hood.
4. Connect control box with pump unit .
5. Check spray width of the atomiser. (see drawing page 3)
6. After checking the output volume (workflow on the right) connect all hoses.

Metering table

Roundup UltraMax application rate at 20°C

Dosing pump Mankar -3 Piston for VARIMANT-4 Plus

km/h	m/min.	l/ha	nominal value ml/min.	pump calibration
4	67	1	3,4	A
		1,5	5	C
		2	6,8	D
6	100	1	5	C
		1,5	7,5	E
		2	10	H
10	166	1	8,25	G
		1,5		
		2		

Checking the output volume

1. Place an underlay (e.g. cardboard or paper) on the ground and prop up the unit on stands.
2. Fill the chemical tank with herbicide –undiluted.
3. Open the pump box and set the chemical solution volume according to the output table.
4. Volume calibration: Collect the chemical solution in a metric measuring cup for one minute. If the desired volume is not reached, set a larger or a smaller volume with pump metering adjustment knob.
5. Perform volume calibration again.
6. Reconnect the hose
7. The unit is now ready for deployment

Dosing pump Mankar -3 Piston for VARIMANT-4 Plus

km/h	m/min.	l/ha	nominal value ml/min.	pump calibration
4	67	1	3,4	A
		1,5	5	C
		2	6,8	D
6	100	1	5	C
		1,5	7,5	E
		2	10	H
10	166	1	8,25	G
		1,5		
		2		

VARIMANT-4 Plus

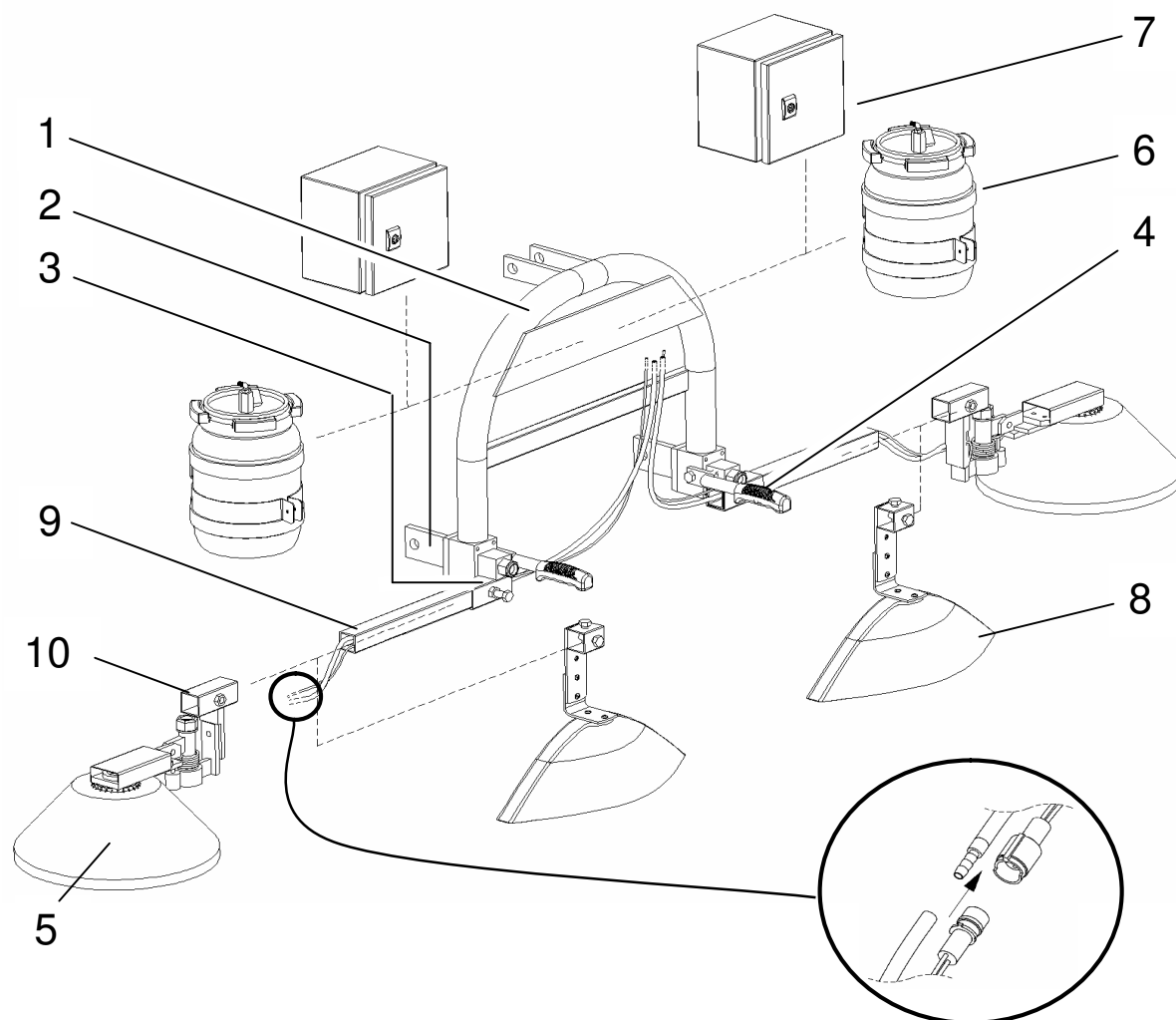

Item Part No. Description

1	101797	3-point hitch for VARIMANT/FLEXOMANT
2	101541	Lower link for 3-point hitch VARIMANT/FLEXOMANT
3	100676	Swivel VARIMANT, left side
3a	101550	Swivel VARIMANT, right side
4	100677	Adjustment with handhold
5	101265	Spray hood arm (K) 36 cm Version: plastics with atomizer
6	100589	Tank subassembly, consisting of: Tank 6L, tank holder, lid and filter for VARIMANT
7	100582	Pump unit MANKAR-3 DC/DC, Capacity 2 x 5 - 12 ml/min
8	100602	Spray hood 45cm for FLEXOMANT-VARIMANT-4 Plus
9	100671	Extension arm VARIMANT
10	101789	Width adjustment, left side
10a	101790	Width adjustment, right side

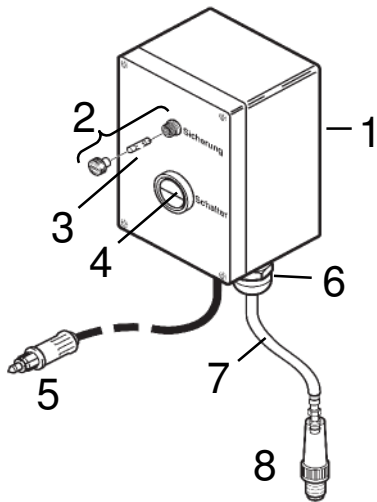

Item Part No. Description

100977 Housing, steel, 200x200x155mm, for control box and pump box

1	101534	Connection box, grey, Typ 1002, WINNER
2	100365	Fuse holder complete
3	100730	Fuse T3.15 Amp
4	101564	Switch with control light
5	100121	Screwed cable gland PG 7, plastic
6	100069	E-cable with 2-core plug
7	101548	Lead 2 x 1,00 mm ² , sold by metre
8	101532	Plug, 7poles

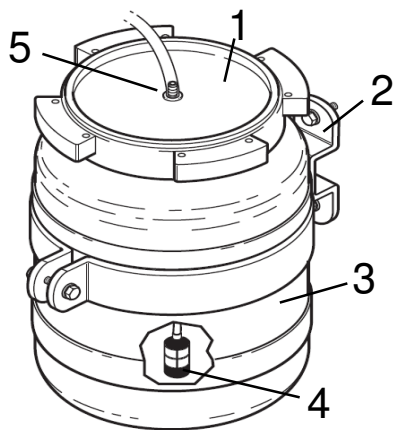

Item Part No. Description

100589 Tank subassembly, consisting of: Tank 6L, tank holder, lid and filter for VARIMANT

1	100625	Tank lid for 6 litre tank
2	100623	Tank holder for 6 litre tank
3	100624	Tank, 6 litre
4	100281	Filter MINI-MANTRA
5	100085	Hose stem

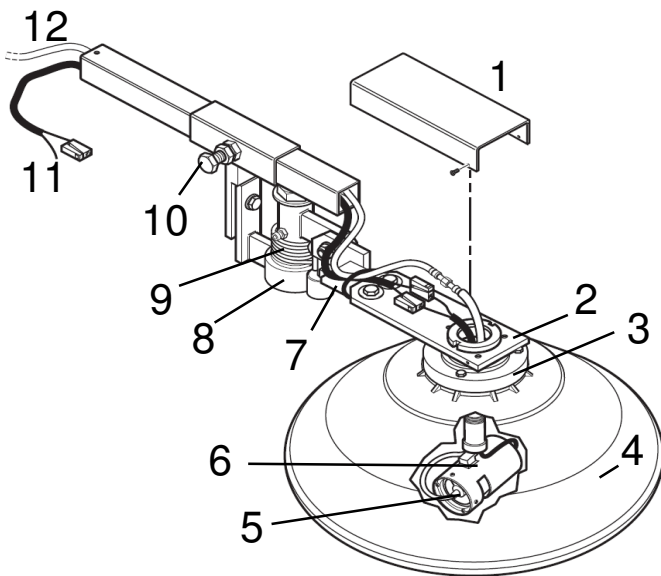

Item Part No. Description

101265 Spray hood arm (K) 36 cm Version: plastics with atomizer

1	100672	Covering sheet
2	100673	Swinging arm for spray hood VARIMANT / FLEXOMANT
3	100571	Cover for ball bearing
4	101175	Spray hood 36 cm Ø for VARIMANT
5	100320	Segmental Atomiser for MANKAR
6	100619	Atomiser protective tube
7	101655	Flange for pivot
8	101825	Pivot for VARIMANT
9	100674	Spring 4 mm for pivot VARIMANT / FLEXOMANT
10	101134	Hexagon screw M 10 x 30 mm galvanized
11	101536	Lead GS/BL 2 x 0,75
12	100885	Tube PVC- , 4 x 2 mm, sold by metre

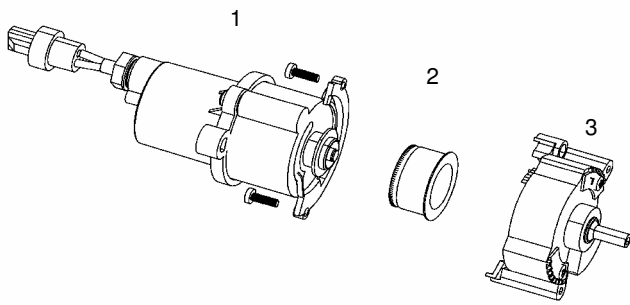

Part Art. No. Designation

100320 Atomiser for MANKAR

1	102417	Motor module for segmental atomiser MANKAR
2	100478	Atomiser disc for herbicide atomiser
3	101996	Segment module for segmental atomiser

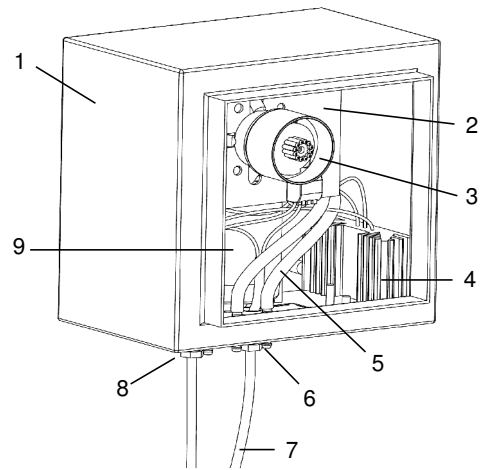

Part Art. No. Designation

100515 Pump unit MAFEX-3 DC/DC Capacity 2-20 ml/min
100582 Pump unit MANKER-3 DC/DC Capacity 2 x 5-12 ml/min

1	100977	Housing, steel, 200x200x155mm
2	102285	Fitting panel for MANKAR pumps
2a	102284	Fitting panel for MAFEX pumps
3	100522	Dosing pump MANKAR-3, capacity 5 - 10 ml/min
3a	101565	Dosing pump MAFEX-3, capacity 2 - 20 ml/min
4	100667	Converter 12V to 6V
5	101284	Tube PVC-, 4x2mm 20cm
6	100085	hose stem
7	101536	Lead GS/BL 2x0,75
8	100121	Screwed cable gland PG 7, plastic
9	100177	Pump motor 12V with Hall-sensor

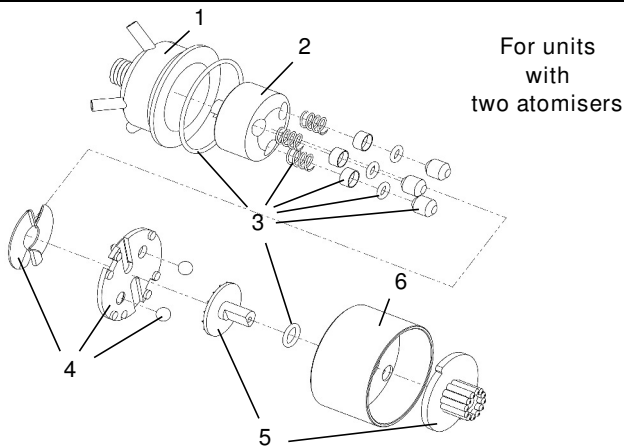

Part Art. No. Designation

100522 Metering pump MANKAR-3, capacity 5 - 10 ml/min

1	100528	Housing, pump housing, MS for MANKAR
2	100138	Rotor-3, MS for piston pumps MAFEX / MANKAR
3	102373	Sealing set for MANKAR/MAFEX-3
4	101626	Repair set, MANKAR metering pump, pressure plate/wobble plate
5	102429	Repair set, MANKAR metering pump, metering adjustment knob/selector disc
6	100534	Cover for piston pump

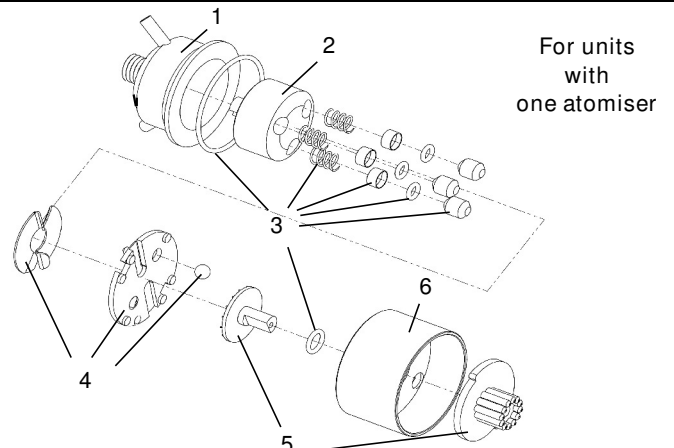

Part Art. No. Designation

100492 Metering pump MAFEX-3, capacity 2 - 20 ml/min

1	100493	Housing, pump housing, MS for MAFEX
2	100138	Rotor-3, MS for piston pumps MAFEX / MANKAR
3	102372	Sealing set for MAFEX-3
4	102436	Repair set, MAFEX metering pump, pressure plate/wobble plate
5	102437	Repair set, MAFEX metering pump, metering adjustment knob/selector disc
6	100534	Cover for piston pump

**Dosierpumpe MANKAR
Metering pump MANKAR
Pompe doseuse MANKAR**

**Dosierpumpe MAFEX
Metering pump MAFEX
Pompe doseuse MAFEX**

**Druckseite
Pressure sleeve
Pression**

**Saugseite
Sucking sleeve
Aspiration**

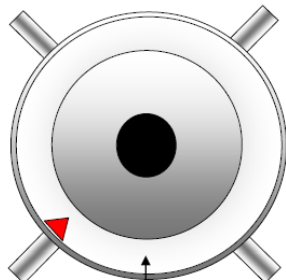

**Saugseite
Sucking sleeve
Aspiration**

**DOSIERKNOPF
Metering adjustment knob**

**Druckseite
Pressure sleeve
Pression**

Druckseite / Pressure sleeve / Pression

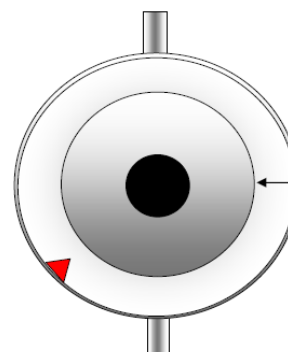

**DOSIERKNOPF
METERING
ADJUSTMENT KNOB
RÉGLAGE DE DÉBIT**

**Saugseite
Sucking sleeve**

Fault remedy

Fault	Cause	Remedy
Atomiser disc not Turning	Atomiser contaminated Fuse blown	Thoroughly clean atomiser, remove plant parts if needed Replace fuse on powerpack (Replacement fuses are located in the powerpack housing)
	No electrical contact Battery defective Atomiser motor defective	Check cable or connector contact Install new battery Install new motor Connect the brown cable to Plus (+).
Atomiser spray one-sided	Rotation disc turning in the wrong direction	Connect cable correctly! Selectively plug the brown cable onto the contact pin on the switch/valve unit Connect the blue cable via the round pin plug. Check to ensure the battery connection to the powerpack is correctly poled, blue cable to Plus (+).
Atomiser spray too wide	Width adjustment improperly set	Loosen the screw F (see page 4) and correct the width setting to the left or to the right, respectively
Atomiser drips	Pump incorrectly set Atomiser disc defective / contaminated Atomiser spray discharge contaminated	Check setting, see table Replace / clean disc Clean
Atomiser foams	Residual water in system	Completely empty container, hose, segmental atomiser.
Chemical not flowing evenly	Filter contaminated	Unscrew filter, clean screen.
Air in hose line	Hose connection / Filter leaking	Slightly shorten the hose and set onto a hose nipple. Re-tighten the screw on the filter.

GUARANTEE

The manufacturer guarantees that in accordance with the present state of technology the article of purchase is free from defects as regards raw materials and construction. Guarantee is valid for all machines and apparatus for 24 months. The period of guarantee begins from the date of purchase by the user.

The manufacturer will decide to repair or replace faulty parts or issue a credit note.

Parts damaged due to normal wear and tear will not be replaced under guarantee. Carriage costs are borne by the manufacturer for faulty goods. Unresolved claims do not entitle purchaser to withhold payments or set them against non-approved claims. Parts not manufactured by manufacturer are guaranteed by the original manufacturer under their terms. Warranty claims must be submitted in writing within 4 weeks of the damage being seen. Repairs will be carried out with original manufacturer spare parts by an approved dealer. Acknowledgement of a claim by manufacturer is binding only when a written notice is issued. Unless the manufacturer cannot make a repair, there is no right to cancellation of orders or to mitigation. Compensation for direct or indirect damage will not be given.

Guarantee terminates if the article of purchase is altered by manipulation of third parties or by installing spare parts of extraneous origin and if the ascertained damage is directly caused thereby. Guarantee also terminates if orderer does not observe the operating instructions. Guarantee does neither apply to natural wear, to damage caused during storage or by corrosion, nor to damage caused by negligent or improper handling. Guarantee does not apply to used machines or apparatus.

The operation instruction published by the manufacturer has been carefully prepared and is based on extensive tests.

Since manufacturer have no influence on installation and handling of apparatus, the company will not assume any responsibility for lack of success or for damages caused by the apparatus itself or by its use.

EG-Declaration of conformity
Council Directive 2006/42/EG

Mantis ULV-Sprühgeräte GmbH, Vierlander Straße 11 a, 21502 Geesthacht declares under our sole responsibility that the following products are in conformity with the provisions of the following Council Directive: 2006/42/EG

Typ	MANKAR-P, MANKAR-110-P, MANKAR-110-GP, MANKAR-L, MANKAR-110 SELECT EL
Typ	MANTRA, MINI-MANTRA / PLUS, MICRO-MANTRA, MICRO-VASO
Typ	FLEXOMANT-1W, FLEXOMANT-2W, FLEXOMANT-3W, FLEXOMANT-4W, FLEXOMANT-PLUS, VARIMANT-1, VARIMANT-2, VARIMANT-4 PLUS, VARIMANT-WINNER-TOP, VARIMANT-WINNER-UNO
Typ	MAFEX
Typ	ROFA

André Verder
Managing Director

Geesthacht January 2009

(Place and date of signature)

(Name, title and signature)